

Experimental Approach to Measure Fuel Quantity in Automobile Vehicles

Prajapati Khushal^{a*}, Suthar Nikhil^a, Tavre Dhruv^a, Panchal Veer^a, Amit Patel^b

^aResearch Scholar, Mechanical engineering department, Gandhinagar Institute of Technology, Gandhinagar, Gujarat

^bAssistant professor, Mechanical department, Gandhinagar Institute of Technology, Gandhinagar, Gujarat

Abstract

The recent times we are constantly hearing about petrol bunk frauds. Most of the petrol bunks today have manipulated the pumps such that it displays the amount as entered but the quantity of fuel filled in the customer's tank is much lesser than the displayed value. Let the pumps are tampered for the benefit of the petrol bunks owner. This results in huge profits for the petrol bunks but at the same time the customers are cheated. All the vehicles in India consist of analog meters hence it is not possible to precisely know the amount of fuel currently in the vehicle and it is not possible to cross check the quantity of fuel filled in the petrol bunk. In this project we focus on creating a digital display of the exact amount of fuel filled in the vehicles tank and helps in cross checking the quantity of fuel filled at the petrol bunk.

Keywords - Fuel tank, Fuel flow Meter, Flow sensor, Digital fuel meter.

1. Introduction

In recent time petrol bunk scams are very common. today manipulate pumps such that it displays the amount as entered almost 80 percentage of the petrol bunks, but in reality, the quantity of fuel filled in the customer's tank is much lesser than the displayed value. Then the customers are being cheated. And petrol bunks are huge profit earning. That found out a proper solution indicating the accurate availability of fuel in the tank is a digital meter this meter calculating proper value of petrol bunks. Some issues to the existing level measurement techniques are identified and try to better alternate digital sensing technology has been suggested all description give below the paragraph and justified this issue.

Product name is fuel flow meter. Product is generally considered as one type of inspection device. Product is measure actual fuel quantity. This product in use flow rate sensor, Arduino UNO, digital display, Potentiometer, battery, etc. product is very simple attractive creative and helpful. This project domain is automobile industry. Product is fuel flow meter manufacturing is very easy. And use making this product material and part is easily available on market, so many advantages, low-cost product. We know that at the petrol pump give as lesser than petrol as we want. So we are going to make a product at an affordable price by which we can measure how many liters of petrol have been discharged in our tank.

2. Literature Survey

The following chapter discusses the literature survey done in fuel flow meter. The chapter further describes history, background and different types of flow meter.

Author S. R. Khan [1] has developed a Real Time Generator Fuel Level Meter Embedded with Ultrasound Sensor and Data Acquisition System. This project has an Ultrasound Sensor module, Liquid Crystal Display to show the updates, a micro-SD card for data acquisition and Real Time Clock to gave accurate time and date. The whole system has controlled by two PIC microcontrollers 18F4520.

V. Rahul [2] has worked on digital fuel indicator system. The author specifies the used of liquid pressure sensor which works on the principle of piezoelectric effect which has calibrated to the fuel tank. Calibration result of the liquid pressure sensor has linear than the Float level sensor and hence it can be used to measure level of the tanks.

P. Geetha [3] has published a paper on Design and Implementation of GSM Based Digital Fuel Meter and Fuel Theft Detection Using PIC Microcontroller PIC16F877A Microcontroller. LCD (16x2) has connected to Microcontroller to display the level of fuel. After ignition LCD will display current value of fuel level.

*Prajapati Khushal

E-mail address: 200120119511@git.org.in

G. Prath yusha [4] published a paper on Embedded Based Flow Control Using Fuzzy YF-S201 Hall Effect Water Flow Meter / Sensor. In this system, sensor placed in line with the water line and contains any simple level sensor. Sensor used to measure how much liquid has pumped through it. There has an integrated magnetic Hall Effect sensor that outputs an electrical pulse. The Hall Effect sensor has sealed that allows the sensor to stay safe and dry. The sensor comes with three wires: red (5-24VDC power), black (ground) and yellow (Hall Effect pulse output). By counting the pulse from the output of the sensor, user can easily calculate water flow.

3. Experimentation

The prototype contains the main body consisting of an external body, a flow meter sensor, an Arduino uno chipset and a digital display. A fluid is passed through the external body, which is connected to flow meter sensor. As the fluid flows through the sensor, it registers the flow of fluid. The registered data then forwarded to the Arduino uno chipset for programming, after programming the data will then be displayed on the digital display. This display shows how much fuel has been poured through the prototype/model. Non-corrosive materials, Arduino uno and 3D software have been used to prepare a prototype. The basic circuit diagram or actual circuit of the fuel flow meter is given in the fig 1 & 2.

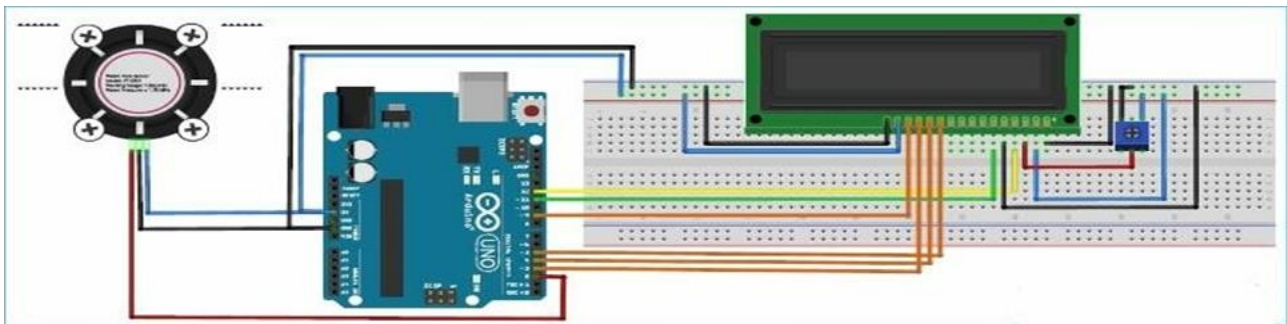

Fig. 1. Circuit Diagram of Fuel Flow Meter

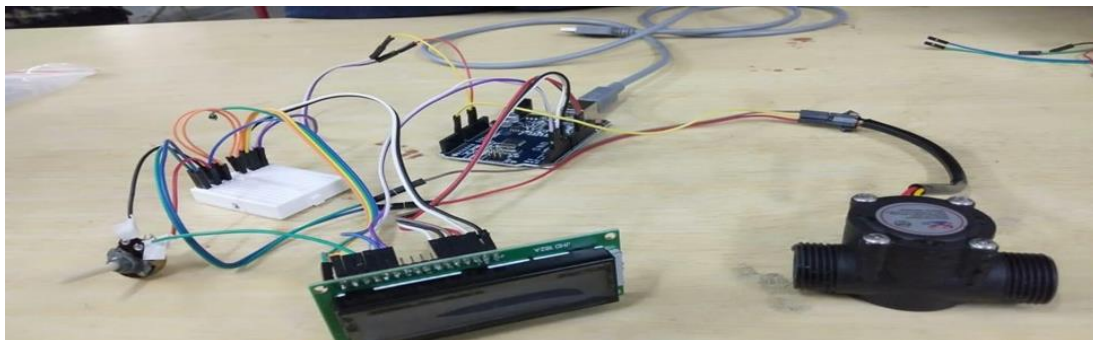

Fig. 2. Actual Circuit of Fuel Flow Meter

3.1 Components

- 1 Flow rate sensor
- 2 Arduino UNO
- 3 Digital display
- 4 Potentiometer
- 5 Battery
- 6 Body

3.1.1 Flow rate sensor

Accurate flow measurement is an essential step both in the terms of qualitative and economic points of view. Flow meters have proven excellent devices for measuring water flow, and now it is very easy to build a water management system using the renowned water flow sensor YF-S201. For example, you can make a robotic cocktail dispensing machine, and can use this sensor to accurately measure components like Soda, Water, etc.

The fig 3 show the YF-S201 1/2-inch Water Flow Sensor sits in line with the water line and contains a pinwheel sensor to measure how much water has moved through it. There is an integrated magnetic Hall-Effect sensor that outputs an electrical pulse

with every revolution. YF-S201 1/2-inch water flow sensor has only three wires and it can be easily interfaced between any microcontroller and Arduino board. It requires only +5V Vcc and gives pulse output, the sensor needs to be tightly fitted between water pipeline.

Specifications of 1/2 inch Water Flow Sensor - YF-S201: -

- Model: YF-S201
- Sensor Type: Hall effect
- Working Voltage: 5 to 18V DC (min tested working voltage 4.5V)
- Max current draw: 15mA @ 5V
- Output Type: 5V TTL
- Working Flow Rate: 1 to 30 Liters/Minute
- Working Temperature range: -25 to +80°C
- Working Humidity Range: 35% -80% RH
- Accuracy: ±10%
- Maximum water pressure: 2.0 MPa
- Output duty cycle: 50% +-10%
- Output rise time: 0.04us
- Output fall time: 0.18us
- Flow rate pulse characteristics: Frequency (Hz) = 7.5 * Flow rate (L/min).
- Pulses per Liter: 450
- Durability: minimum 300,000 cycles



Fig. 3. Flow Rate Sensor

3.1.2 Arduino UNO

Arduino Uno is a microcontroller board based on the ATmega328P (datasheet). The fig 4 Arduino UNO It has 14 digital input/output pins (of which 6 can be used as PWM outputs), 6 analog inputs, a 16 MHz quartz crystal, a USB connection, a power jack, an ICSP header and a reset button. It contains everything needed to support the microcontroller; simply connect it to a computer with a USB cable or power it with an AC-to-DC adapter or battery to get started. You can tinker with your UNO without worrying too much about doing something wrong, worst-case scenario you can replace the chip for a few dollars and start over again. "Uno" means one in Italian and has been chosen to mark the release of Arduino Software (IDE) 1.0. The Uno board and version 1.0 of Arduino Software (IDE) were the reference versions of Arduino, now evolved to newer releases. The Uno board is the first in a series of USB Arduino boards, and the reference model for the Arduino platform; for an extensive list of current, past or outdated boards see the Arduino index of boards.

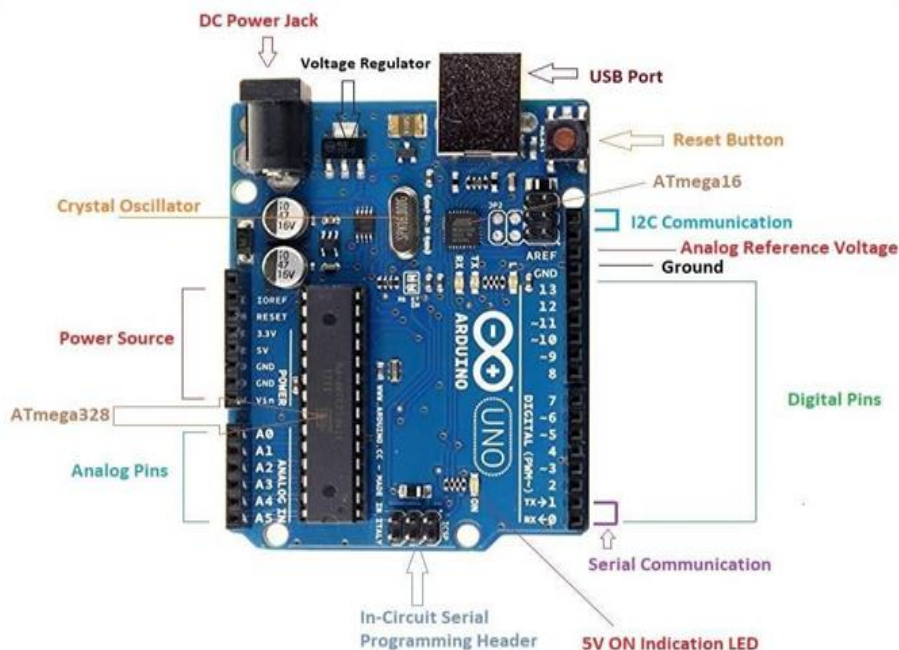

Fig. 4. Arduino UNO.

3.1.3 Digital display

The show in fig 5 LCD, we are using a high quality 16 characters by 2-line display module, with back lighting.

- 16 Characters x 2 Lines
- HD44780 Equivalent LCD
- Controller/driver Built-in
- 4-bit or 8-bit MPU Interface
- Standard Type
- Works with almost any microcontroller.



Fig. 5. Digital Display

3.1.4 Battery

This is general 9v Battery as show in fig 6 for all your project and application needs. Whether you need a new battery for your applications like a Flashlight, Portable Phone Charger, Wireless doorbell, Wireless audio transmitter-receiver systems or your kid's toys, etc. or even if you are looking for

A long-lasting, reliable option for your sensor devices like a smoke detector, everyone needs a good 9-volt battery every once in a while. It's also a great idea to keep extra 9-volt batteries around in case of an emergency. That's why we've found one of the best 9-volt battery available.



Fig. 6. Battery

3.1.5 Potentiometer

10k ohm Trim pot RM065 Package is a type of variable resistor, the show in fig 7 potentiometer it can be easily mounted on PCB and adjusted using screwdriver.



Fig. 7. Potentiometer

3.2 Programming

The explanation of the code is as follows.

We are using the header file of the LCD, which eases our interfacing the LCD with Arduino, and the pins 12,11,5,4,3,9 are allotted for data transfer between LCD and Arduino. The sensor's output pin is connected to pin 2 of Arduino UNO.

This function is an interrupt service routine, and this will be called whenever there is an interrupt signal at pin2 of Arduino UNO. For every interrupt signal, the count of the variable flow frequency will be increased by 1.

In the void setup, we tell the MCU that the pin 2 of the Arduino UNO is used as INPUT by giving command pinMode (pin, OUTPUT). By using attach Interrupt command, whenever there is a rise in the signal at pin 2, the flow function is called. This increases the count in the variable flow frequency by 1. The current time and cloopTime are used for the code to run in every 1 second.

If the function ensures that for every one second the code inside it runs. In this way, we can count the number of frequencies produces by the flow rate sensor per second. The flow rate pulse characteristics from the datasheet are given that frequency is 7.5 multiplied by flow rate. So, the flow rate is frequency / 7.5. After finding flow rate which is in liters/minute, divide it by 60 to convert it into liter/sec. This value is added to the vol variable for every one second

3.3 Prototype



Fig. 8. Fuel Flow Meter

4. Results & Discussion

With using the arrangement, we performed trials by pouring petrol through the device hence getting results as follows.

Table 1. Experimental results of fuel flow meter.

Sr No.	Fluid Type	Actual Quantity (Ltr)	Reading Quantity (Ltr)	Percentage Error (%)
1	Petrol	0.16	0.14	12.5
2	Petrol	0.50	0.44	12.5
3	Petrol	0.75	0.66	12.0
4	Petrol	1	0.88	12.0

After getting problems we tried to solve the issue and we firstly, used brass Pipe connector on both side of the fuel sensor, after performing trials we got the results but were not satisfactory, so then we used an arrangement of 2-3 pipes with different dimensions where the inlet pipe's diameter is maximum and outlet pipe's diameter is minimum and then again, we performed trials with getting better results and better accuracy.

5. Conclusion and Future scope

After completing, solution is figured out to overcome the problem and limitation in order to make our prototype run smoothly and successfully. Besides, students are able to have more understanding about the working of fuel flow meter. Furthermore, students

also have understood about the advantages and disadvantages of fuel flow meter. Product is fuel flow meter which performs very accurate and excellent.

As the project is new in country, there is a golden scope for this project. The project is helpful to other people to purchase it as per their requirement. Second strength of this project is its low production cost, this leads to allow to purchase it for their work. It is very simple to use. If any failure occurs in the part of this product, it can be changed as its construction is simple and not costly. Its maintenance cost is also very low. Hence, as we all have learned about the increase in the price of fossil fuel especially fuel used to run automobile vehicles, every drop of the fuel is very important for a common man considering the economic situation of every household. To ensure that we get the correct amount of fuel for the sum we paid, we introduce a product in form of our project that will tell how much quantity of fuel has actually gone in the vehicle. We are aware that these types of instruments are already available in the market but the problem with them is that they are very expensive and common public cannot afford them. So, the goal of our project is to provide common public a device which is accurate is very affordable and is easy to use.

References

1. Sadeque Reza Khan, Arifa Ferdousi, Siddique Reza Khan “Real Time Generator Fuel Level Measurement Meter Embedded with Ultrasound Sensor and Data Acquisition System” in Journal of Automation and Control Engineering Vol. 1, No. 4, December 2013.
2. Rahul S. Vaidya “Digital Fuel Level Indicator”, Journal of Information, Knowledge and Research in Mechanical Engineering, Vol. 04, Issue-01, Nov 15.
3. P. Geetha bai ME., L. Deepika, M. Dharani, P. Haripriya, G. Lavanya “Design and Implementation of GSM Based Digital Fuel Meter and Fuel Theft Detection Using PIC Micro controller”, Journal of Electronics and Communication Engineering, e-ISSN: 2278-2834, PP 11-14.
4. R. Hari Sudhan, M. Ganesh Kumar, A. Udhaya Prakash, S. Anu Roopa Devi, P. Sathiya “ARUINO ATMEGA-328 MICROCONTROLLER”, International Journal of Innovative Research in Electrical, Electronics, Instrumentation and Control Engineering, Vol.3, Issue 4, April 2015.
5. Leo Louis “Working Principle of Arduino and Using It as A Tool For Study And Research”, International Journal of Control, Automation, Communication and Systems, Vol. 1, No. 2, April 2016.

Acknowledgment: We are very thankful to Dr. H.N. Shah (Director, Gandhinagar Institute of Technology) and Prof. Jatin M Patel (Assistant Professor, Gandhinagar Institute of Technology) for providing all kinds of support at all the level.